

Service Bulletin 15

<h1>Service Bulletin</h1>		
1. General		
(a) Service Bulletin No.:	15	
(b) Revision / Date	Revision 0 - 04 Oct 2007	
(b) Title:	Triple and Quadruple Burner Frames -Weld Inspection	
(c) Description:	Detailed visual inspection of weld at gimbal bearing (triple burner frame cross bar) and attachment of cross bar to outer frame (triple and quadruple burner frames).	
(d) Applicability:	Triple and quadruple burner frames (centre gimbal burner type only).	
(e) Effectivity:	All CN's	
<p>Note: Applicability= All types and variants to which the change can be applied. Effectivity= Actual CN or group of CN's to which the bulletin has been/will be applied.</p>		
2. Background		
<p>Weld failures have occurred in these frames due to inappropriate ground handling eg repeatedly dropping basket including mounted burner off trailer.</p>		
3. Compliance (Category)		
<p>Highly Recommended- within 30 Days.</p>		
4. Consequences of Non-Compliance(Possible)		
<p>Burner unit may become partially or fully separated from frame.</p>		

Service Bulletin 15

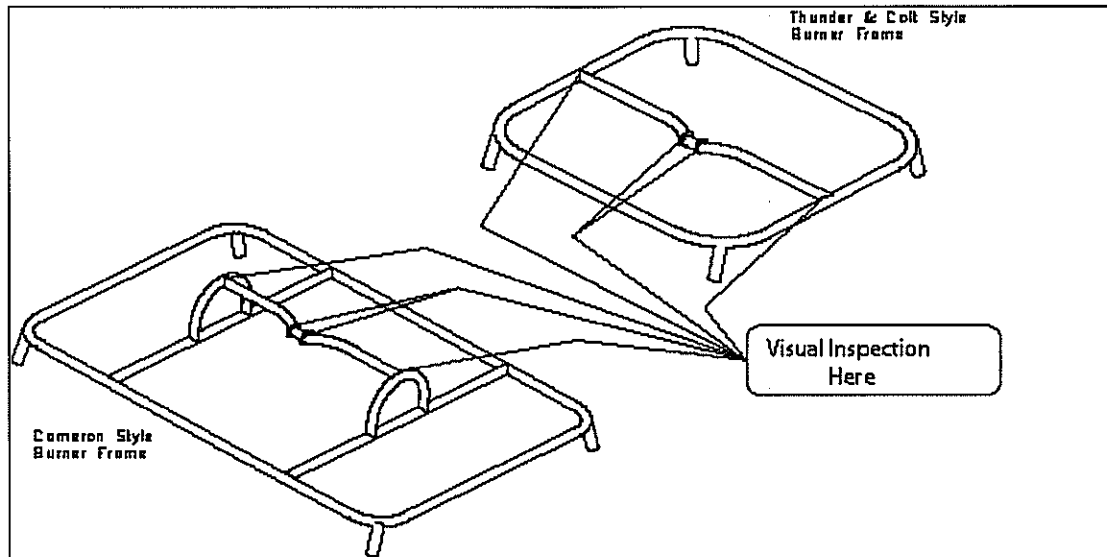

Figure 1

5. Accomplishment Instructions

1. Visual inspection through 360° at weld around gimbal bearing (triple burners only) and at attachment of cross bar to bridges on outer frame (triple and quadruple burners). This may be carried out by the pilot. Refer to Figure 1.
2. Remove from service any frame showing signs of cracking.
3. Report any rejections to Cameron Balloons Ltd. (CBL).
4. Cracked burner frames can be returned to service by incorporation of modification C484.
5. Inappropriate ground handling of basket to be discontinued.

6. *Materials* None

7. *Other Publications Affected* None

8. *Mass(Weight)/Balance:* Not Affected

Service Bulletin 15

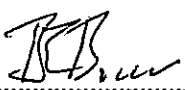
10. Additional Information	
Compiled by: 	Notes:
Date: 04 Oct 07	Name: B.E. Bower

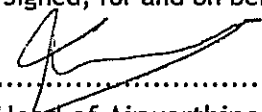
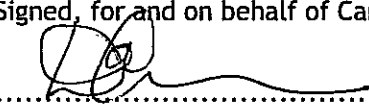
11. Design Organisation Approval	
Statement of Compliance Verification	
I hereby confirm that the instructions identified in this bulletin provide for practical and well defined installation/inspection methods and when accomplished the product is in conformance with approved design data.	
Signed, for and on behalf of Cameron Balloons Ltd.	
	
Head of Airworthiness PP	
Date: 05 Oct 07	Name: F-J-DAVIES
Approval Statement	
I hereby confirm that these instructions are in compliance with all the applicable airworthiness requirements. The technical content of this document is approved under the authority of DOA nr EASA.21J.140	
Signed, for and on behalf of Cameron Balloons Ltd.	
	
Head of Design	
Date: 10 Oct 07	Name: D.A. Cameron

Note: If this Service Bulletin is or will become an Airworthiness Directive, a statement to that effect must be entered in Section 10 of this form.